

Colour hybrid recorder *alpha-log*

Universal compact recorder,
1 to 6 analogue inputs, with automatic
wind up system for 64 m roll chart paper

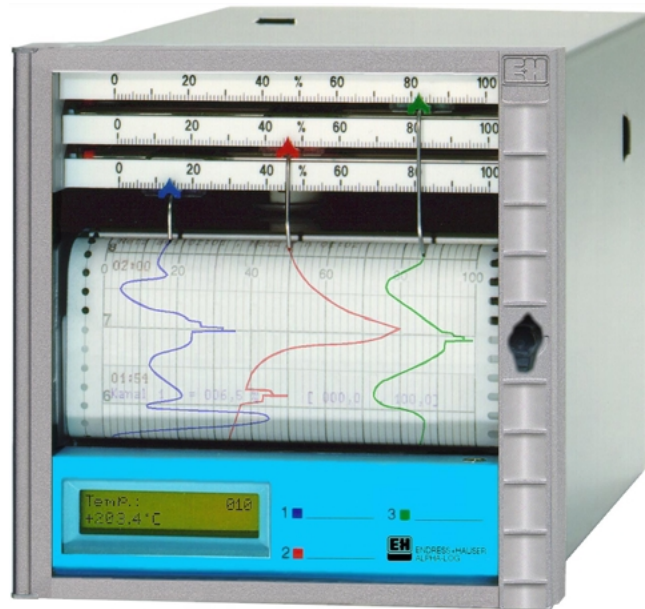

Application areas

The Alpha-Log is a fully programmable process recorder designed for universal application:

- for reliable long term recording and monitoring analogue signals
- in front-end control panels with long maintenance intervals
- due to simple installation (even in small panels) and easy setting up
- quick and easy access to the plotted paper
- in central control stations and panels
- in chemical, industrial and environmental applications as well as air conditioning, quality assurance, energy suppliers, system and plant contractors, OEM and laboratory applications.

Advantages at a glance

- Versatile: All usual measurement signals can be directly connected (bipolar current/voltage, thermocouples and RTDs).
- Low maintenance: Standard roll chart paper, up to 64 m with push button operated automatic wind up.
- Compact: 144x144 mm bezel (IP54), installation depth 215 mm.
- Practical: Push button dialogue operation for PC setting up.
- Informative: Dual display concept with analogue and digital display.
- Reliable: Limit and self monitoring functions including printouts
- Interference free: Complies to EMC requirements to NAMUR and EMVG (with CE mark)
- Universal: Wide range power supplies 90-253 V, 10-30 V AC/DC



Versions

The units in the Alpha-Log series are available in various models.

A choice of one to six galvanically isolated analogue inputs is available.

Number of analogue inputs	Signal record using line plot module (continuous coloured lines)	Signal record using dotting module (dotted coloured lines)	Number of (different) scaled displays for instantaneous analogue values
1	1		1
2	2		2
3	3		3
4	3	1	3
6		6	4

Option package contents

	Option alphanumeric	Option digital I/O
Alphanumeric printout	X	
Real time clock	X	
Summer/normal time automatic	X	
4 alarm relays		X
4 control inputs		X
Rear panel mounted RS485 interface		X
Auxiliary voltage output		X
Limit monitor active: - Printout of presettable text lines - Paper feed speed change including printout - Relays	X X	X
Paper end monitor/fault switches a relay		X

Function

Analogue inputs

The analogue inputs are measured in a frequency of 125 ms/channel. They are galvanically isolated from each other as well as the system and can be digitally calibrated by operating a push button. Due to the universal input all nominal analogue signal types (standard signals, +/- voltage or current, Pt100, Pt500, Pt1000 or thermo couples) can be directly connected. Thermocouples and 4...20 mA current loops are monitored for cable open circuit. This feature can be switched off.

The display informs the operator by means of a scrolled text; the plot is on the left paper margin. If the unit is removed from the housing the current circuit is not broken. Controllers and other components are also not affected.

Paper / handling

The Alpha-Log records using 64 m long standard roll chart paper. This means that the in comparison to other units the paper change interval is greatly extended.



Chassis, opened

Function

Normal 32 m long roll chart paper can also be used. Paper access is made simple by dividing the chassis into three components (hinges upwards and downwards). The plotted paper can also be easily removed during operation and then rewound by operating one of the front panel push buttons. This makes regular check and monitoring of the measured values easier.

Using the digital I/O option paper end is recognised and can be retransmitted via relay 1.

Display

The dual display concept combines a 2x16 digit LC display (for dialogue operation, measured value display and event message text) with linear scales for analogue measured value display. A sheet of adhesive scales with the most used dimensions is delivered with each unit. Included on these sheets are also undimensioned scales with various divisions. These can be easily written on and matched to the application. These sheets are then completed by the addition of adhesive engineering units (°C, l/s, uS/cm, ...).

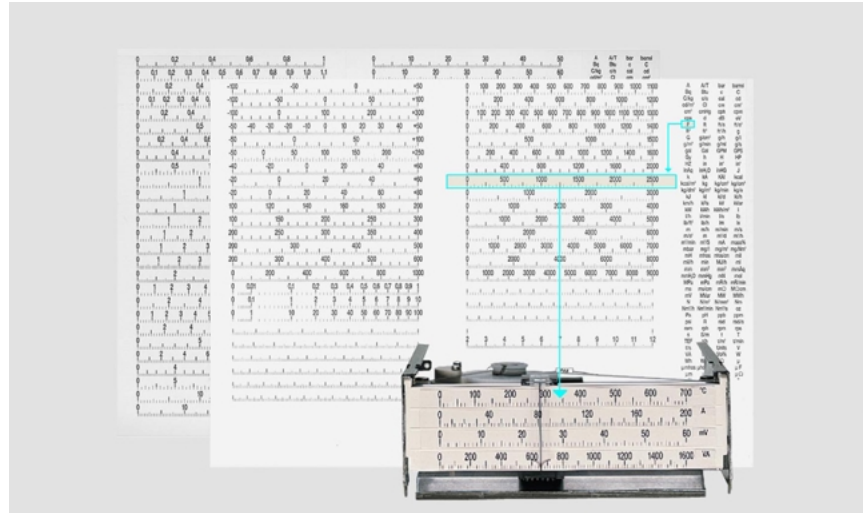

Adhesive scales

Unit settings

The unit can be matched to your application by means of the front panel push buttons. This is done in text dialogue on the display (German, English or French can be selected). A security code avoids unauthorised manipulation of the unit.

Front mounted interface / PC software ReadWin

The Alpha-Log is very quick and simple to set up due to the front mounted serial interface. This is done by using the delivered PC software ReadWin. This software is delivered with the interface connection cable.

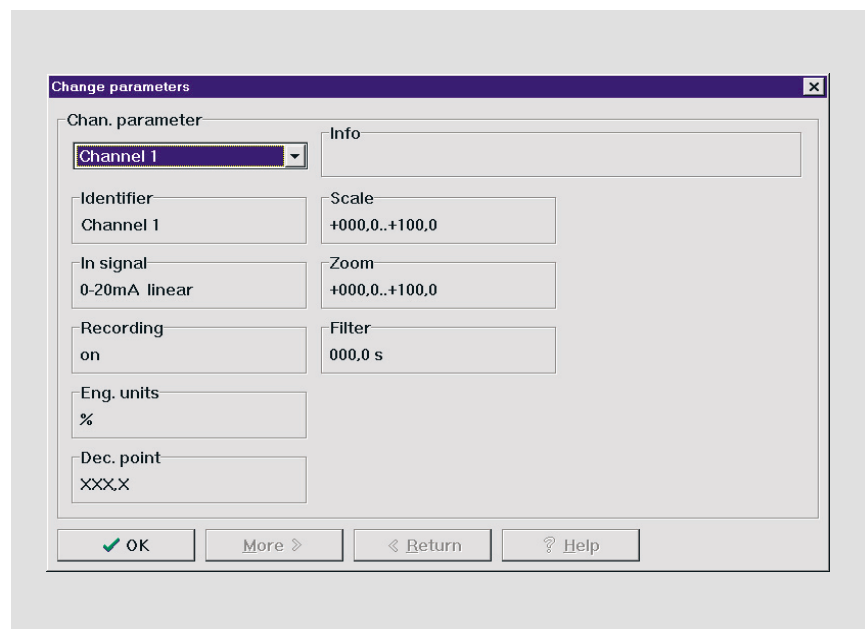

ReadWin screen.
In this example:
Changes to
"Channel parameter"
(the identifier "KANAL 1"
is to be changed)

Function

Housing / front door / connections

The robust stainless steel housing offers the best possible protection to outside influences.

The sturdy front door (protection class IP 54) enables easy access to paper, pens and operating elements even when mounted directly next to one another.

Recessed screw plug in terminal strips ensure easy connection and cable runs even in narrow housings with an installation depth of only 215 mm.

Text printouts (Option "Alphanumeric printout")

Complement your measurements with printout of:

- Date and time (at least 50 hours reserve, battery free buffer using "Gold Cap"),
- Measurement point identifier or tag number,
- Unit installation point / unit identifier,
- Instantaneous values (cyclically),
- Zoom area with engineering units,
- Paper feed rate,
- Presettable event text lines such as
- monitoring and printout of limit infringements (min./max. per channel).
- Paper feed rate change on limit infringement (with printout from date/time and new feed rate).
- Power failure monitor with printout.

Digital in / outputs (Option "Digital I/O")

Alpha-Log can be delivered fitted with optional digital in / outputs. This option contains 4 control inputs, 4 relay outputs and a rear panel mounted RS485 system interface.

The following can be controlled using the 4 inputs:

- Printout of the instantaneous values, presetable event text lines or date / time.
- Recording start/stop times (only limit monitor and paper feed rate),
- Change to "external" paper feed rate,
- Lock and release of setting up using the front panel mounted push buttons.

The 4 relays (3A, 250 VAC) transmit limits or paper end and can be independently defined as closing or opening contacts.

When using the system interface (RS485) connection can be made to higher intelligence systems. The distance between these can be up to 1000 m.

Using the ReadWin PC-Software you can do the following on the Alpha-Log:

- Remote setting up (even by Modem),
- Read out instantaneous values and
- connect it to other Endress+Hauser recording instruments.

Setting up using
PC operation software
Top:
Using cable connection
(approx. 1m) incl operating
software. Can be purchased as
accessories
Bottom:
Example of remote setting up
(max. 32 units) in connection
with the digital I/O option.

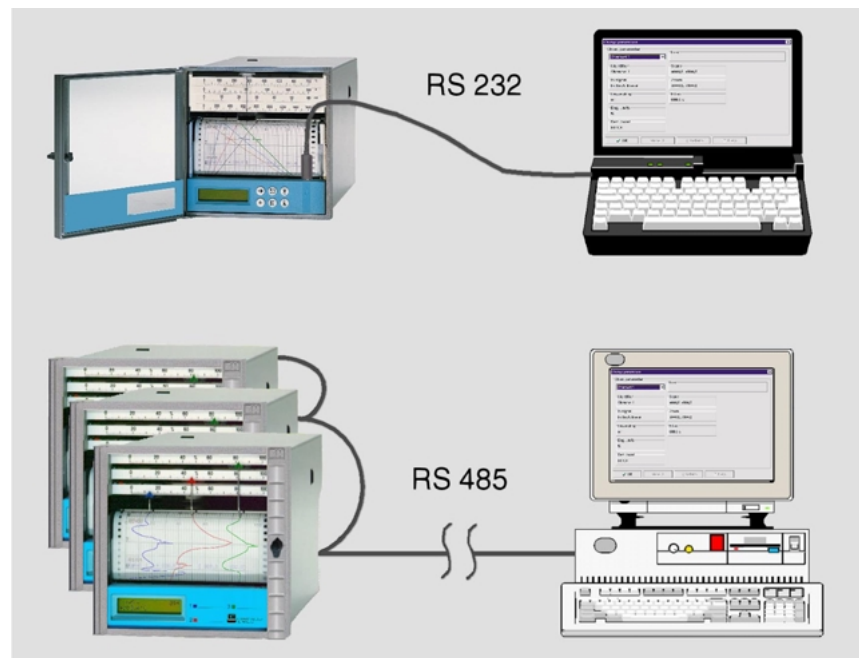

Recording / plot modules

Depending on the required version the unit is delivered with either 1 to 3 colour line modules or a 6 colour dotting module.

If the option "alphanumeric printout" is

used an additional dotting pen (only on line recorders) is used. This pen can also be used as an additional dotting channel (for slow changing signals) So turn a 3 channel recorder into a 4 channel one.

Function

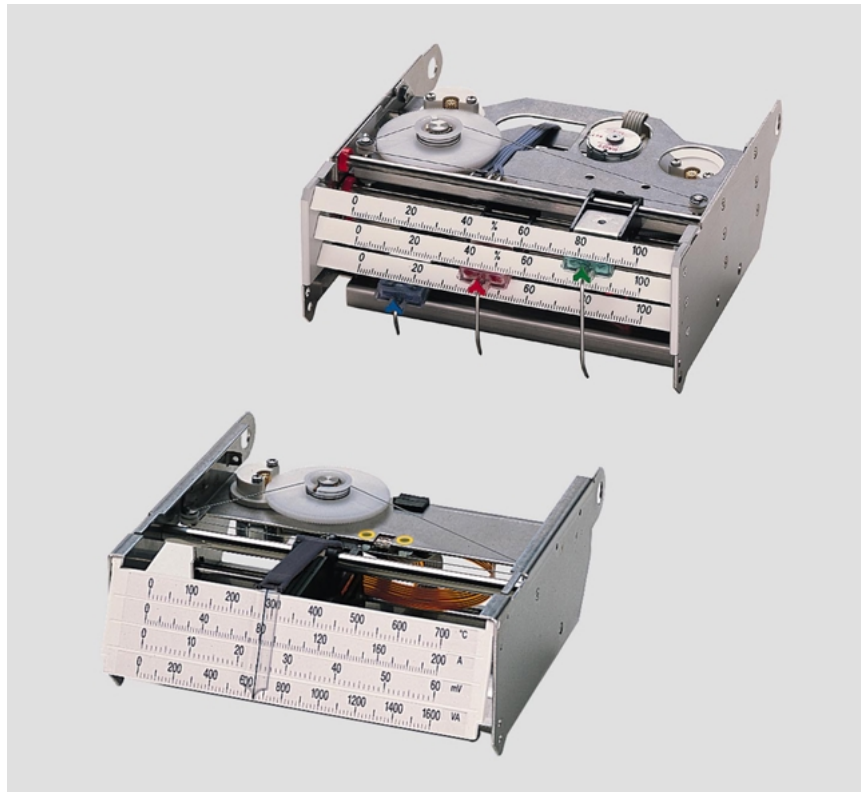

Recording modules:
Top line strip chart recorder
Bottom dotting recorder

Each channel has its own pen,
The dotting recorder print head
operates using 6 integrated linearly
placed coloured pens.
In order to protect the environment we
only use formamide free ink.

The time offset compensation
(switchable) ensures all channels are on
the same time reference.

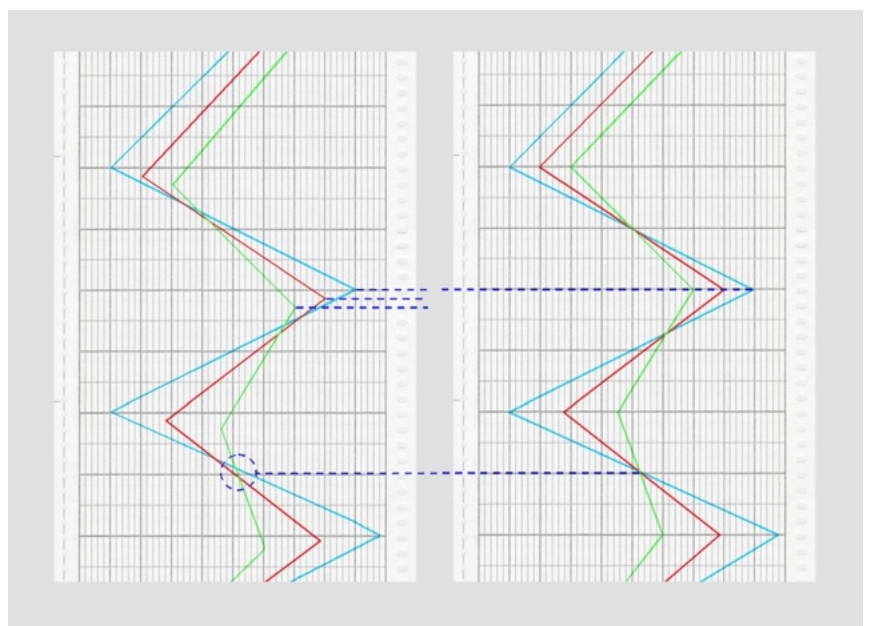

Left strip chart is without time
offset compensation
Right strip chart is with time
offset compensation
switched on

Strip chart examples

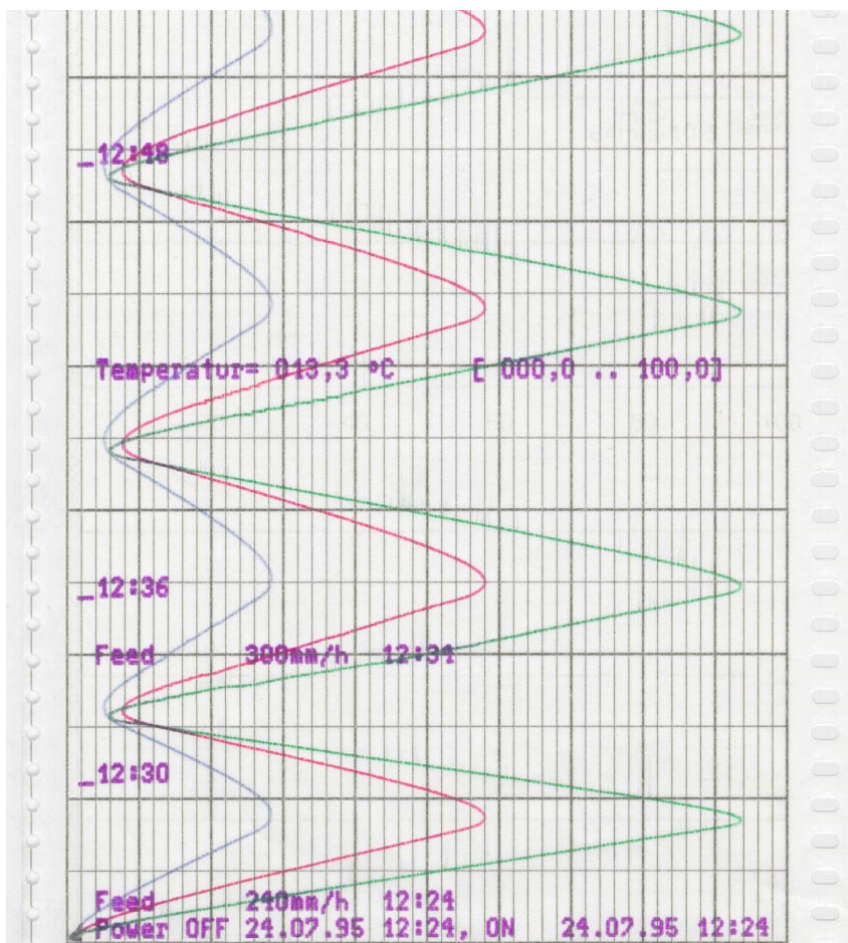

Alpha-Log, line strip chart recorder with "Alphanumeric" option

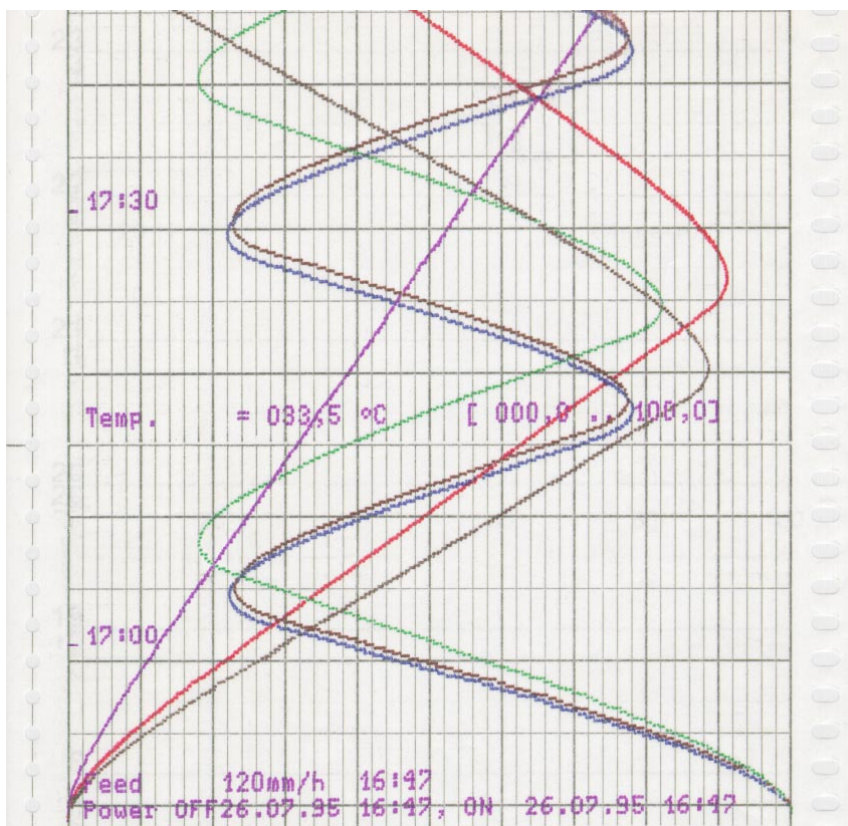

Alpha-Log, dotting recorder with "Alphanumeric" option

Installation / housing

144x144x215mm panel mounted unit
 Panel cutout required
 138⁺¹ x 138⁺¹ mm

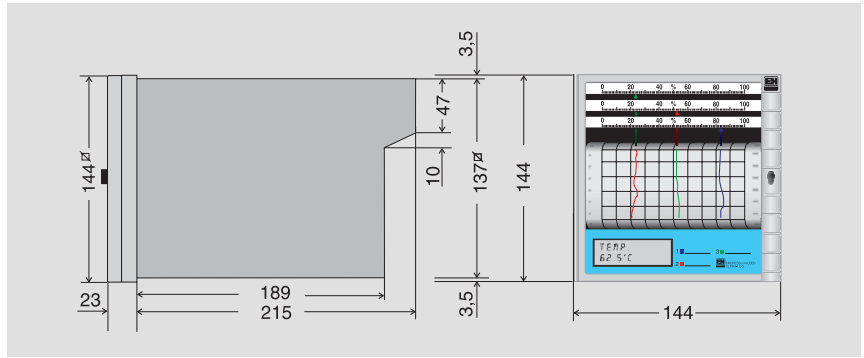

Terminal connections

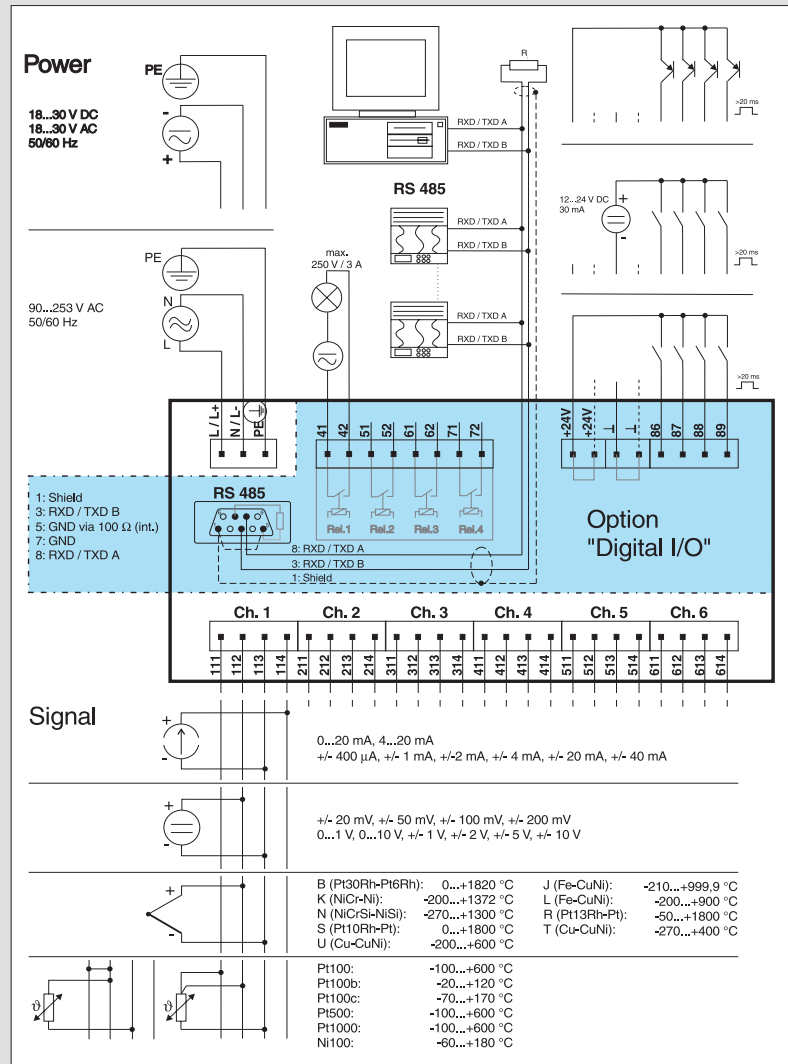

Possible connections,
 Alpha-Log rear panel

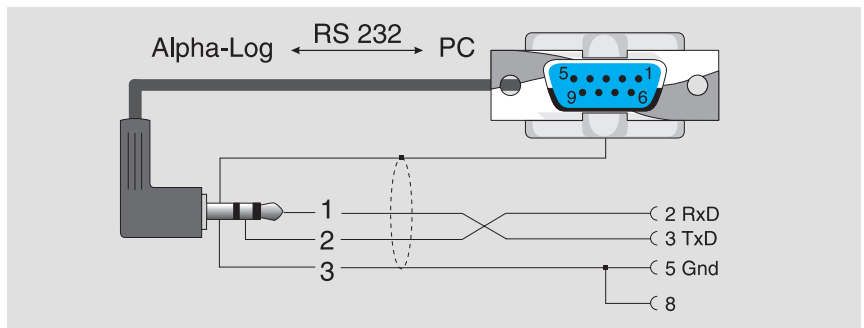

RS 232 connection cable
 (available as accessory).
 9 pin sub-D connector DIN
 41652, with approx. 1 metre
 cable connected to a 3.5 mm
 stereo plug.

Technical data

Measurement unit

Scan cycle	125 ms / channel
Resolution	15 Bit
Accuracy	Base accuracy: +/- 0.25 % FSD Power up drift: +/- 0.2 % FSD Temperature drift: +/- 0.25 % FSD
Measurement range	Voltage (max. 50 V): 0...1 V, 0...10 V, +/- 20 mV, +/- 50 mV, +/-100 mV, +/-200 mV, +/- 1 V, +/- 2 V, +/-5 V, +/- 10 V, Input impedance = 1 MOhm Current (max. 100mA): 0...20 mA, 4...20 mA (cable open circuit monitor <=2mA) Input impedance 50 Ohm (on rear panel circuit board) RTD (DIN 43760 / DIN IEC 751): Pt100, Pt500, Pt1000: -100...+600 °C Ni100: -20...+120 °C Connection in either two or three wire versions Measurement current approx. 1mA Cable compensation (three wire version): <=50 Ohm Thermo couples (DIN IEC 584): Type B (Pt30Rh-Pt6Rh): 0...+1800 °C Type J (Fe-CuNi): -210...+1200 °C Type K (NiCr-Ni): -200...+1372 °C Type L (Fe-CuNi): -200...+ 900 °C Type N (NiCrSi-NiSi): -270...+1300 °C Type R (Pt13Rh-Pt): -50...+1800 °C Type S (Pt10Rh-Pt): 0...+1800 °C Type T (Cu-CuNi): 270...+ 400 °C Compensation points (DIN IEC 584) selectable: Internal compensation of the terminal temperature (additional max. error: +/- 5 K), or external: 0 °C, 20 °C, 50 °C, 60 °C, 70 °C, 80 °C Cable open circuit monitor (DIN IEC 584): >appro. 50 kOhm, Plot on lower chart margin.
Max. allowable potential difference	Channel to channel: DC 60 V, AC 60 V (only safe low voltages)
Damping	Prestable time constant: 0...999.9 seconds, System base damping: Can be ignored
Climatic	To IEC 654-1: B2 Operating temperature: 0...+50 °C Storage temperature: -20...+70 °C Rel. humidity: 10...75 %, max. water content: 0.02 kg / kg dry air Recording paper: To DIN 16234
Mechanical effects	Tested to class V.S.1 to IEC 654-3: v <3 mm/s, 1 < f <150 Hz:
EMC/immunity	To NAMUR recommendation NE 21: - ESD (electrostatic discharge): IEC 801-2: level 3 (6/8 kV) - Electromagnetic fields: IEC 801-3: level 3 (10 V/m) * - Burst (electrical fast transient): IEC 801-4: level 3 (2 kV) - Surge: IEC 801-5: 2kV asym. / 1kV sym. - Surges (HF discharge): IEC 801-6: 10 V * - Power failures: <=20 ms * Additional deviations <= 2%
Normal mode noise rejection	40 dB at input range/10 (50 Hz / 60 Hz +/-0.5 Hz), not on resistance measurement
Common mode noise rejection	<=0.2 % measurement span at 60 Vp (50/60 Hz +/-0.5 Hz)
RF protection	To EN 55022/VDE 0878 Part3: Class A
Plot module	Stepper motor controlled drive with non contact servo system for pens and print head Response time <=2 seconds, resolution = 0.1 mm, dead band (line recorder) <=0.2 mm Switchable time offset compensation (line recorder)

Influencing effects

Recording unit

Technical data

Recording unit

Option "Digital I/O"

Option "Alphanumeric printout"

Display

Operation

Power supply

Housing

Continuation plot system	Recording using 1 to 4 exchangeable pens or 6 chamber print head with formamide free ink Colour sequence line plot system: Channel 1: blue, channel 2: red, channel 3: green, Ink capacity: approx. 600 metres (under reference conditions) Alphanumeric pen (channel 4): violet, Ink capacity: 1 million dots Colour sequence dotting print head: Channel 1: violet, channel 2: red, channel 3: black, channel 4: green, channel 5: blue, channel 6: brown, Ink capacity: 1 million dots per colour (under ref. conditions)
Paper transport	Feed types: Standard, event (limit controlled), external (with option "Digital I/O"): on contact closure at control input All presettable to: 0, 5, 10, 20, 60, 120, 240, 300, 600 mm/h, max. feed tolerance 150 ppm
Channel identifier	Coloured signal traces; on option "Alphanumeric printout": Cyclic printout of channel identifier and selected zoom range
Plot range / zoom per channel	Visible diagram length: approx. 60 mm Zoom: Scaled signal range (in engineering units), selectable in steps of 0.1 %
4 control inputs	To DIN 19240: Input resistance approx. 10 kOhm Logic "0" equals -3...+5V. Activate with logic "1" (equals +12...+30V, Length > 20 ms, Bounce time < 5ms) Selectable functions: Lock front panel setting up Additional functions only with option "Alphanumeric printout": Printout of date / time, instantaneous values, event text, Feed rate change, recorder stop
4 relay outputs	Closing contact (can be set up as opening contact) 250V, 3A
RS 485	System interface (rear panel), cable length max. 1000 m Presettable unit address
Real time clock	Battery free buffer (Gold Cap) on power failure at least 50 h Summer/normal time compensation
Text printout	Date and time, measurement point identifier, unit identifier, instantaneous values, engineering units, zoom area, feed rates, 12 presettable event text lines, limit infringements, paper feed rate changes, power failure times (on/off)
Display	Dual display concept: Scale display and 2x16 character digital LC display Scales: 91 exchangeable adhesive scales (printed and neutral) and 186 engineering units; neutral scales, writable LC display: Text indication Operating languages: German, English, French, selectable
Operating elements	Dual set up: Selectable operation from the unit front by either 6 operating push buttons in dialogue with the integrated display, or unit setting up using PC software ReadexA via front mounted serial RS232 interface. Remote setting up using option "Digital I/O" via rear panel mounted serial RS485 system interface
Power supplies	Normal voltage supply: 90...253 VDC, AC 90...253V / 50/60 Hz, max. 15 VA Low voltage supply: 18...30 VDC, AC 10...30V / 50/60 Hz, max. 15 VA
Safety	IEC 1010-1 / EN 61010-1 / VDE 0411 Part 1, Protection class I, Overvoltage category II
Primary fuses	315 mA (Normal voltage supply)
Model / weight	Stainless steel V2A, for panel mounting (2... 40 mm), Front bezel: 144x144 mm, Installation depth: 215 mm. Fixed with two jack screws (delivered). Total weight: 4 kg
Front door	Metal frame with rubber gasket, protection class IP 54 to IEC 529 / EN 60029, glass viewing window
Connections	Keyed screw plug in terminal strips, Wire cross section max. 2.5 mm ²

Technical alterations reserved.

